

REPORTE TÉCNICO DECRETO SUPREMO N°38/11 DEL MINISTERIO DEL MEDIO AMBIENTE
 Establece Norma de Emisión de Ruidos Generados por Fuentes que Indica

FICHA DE INFORMACIÓN DE MEDICIÓN DE RUIDO

IDENTIFICACIÓN DE LA FUENTE EMISORA DE RUIDO

Nombre o razón social	Banco Estado de Chile		
RUT	97.030.000-7		
Dirección	Providencia		
Comuna	1710		
Nombre de Zona de emplazamiento (según IPT vigente)	UpEC, Uso preferentemente Equipamiento Comercial		
Datum	WGS84	Huso	19S
Coordenada Norte	6300297.45 m	Coordenada Este	349804.52 m

CARACTERIZACIÓN DE LA FUENTE EMISORA DE RUIDO

Actividad Productiva	<input type="checkbox"/> Industrial	<input type="checkbox"/> Agrícola	<input type="checkbox"/> Extracción	<input type="checkbox"/> Otro
Actividad Comercial	<input type="checkbox"/> Restaurant	<input type="checkbox"/> Taller Mecánico	<input type="checkbox"/> Local Comercial	<input type="checkbox"/> Otro
Actividad Esparcimiento	<input type="checkbox"/> Discoteca	<input type="checkbox"/> Recinto Deportivo	<input type="checkbox"/> Cultura	<input type="checkbox"/> Otro
Actividad de Servicio	<input type="checkbox"/> Religioso	<input type="checkbox"/> Salud	<input type="checkbox"/> Comunitario	<input checked="" type="checkbox"/> Otro
Infraestructura Transporte	<input type="checkbox"/> Terminal	<input type="checkbox"/> Taller de Transporte	<input type="checkbox"/> Estación Intermedia	<input type="checkbox"/> Otro
Infraestructura Sanitaria	<input type="checkbox"/> Planta de Tratamiento	<input type="checkbox"/> Relleno Sanitario	<input type="checkbox"/> Instalación de Distribución	<input type="checkbox"/> Otro
Infraestructura Energética	<input type="checkbox"/> Generadora	<input type="checkbox"/> Distribución Eléctrica	<input type="checkbox"/> Comunicaciones	<input type="checkbox"/> Otro
Faena Constructiva	<input type="checkbox"/> Construcción	<input type="checkbox"/> Demolición	<input type="checkbox"/> Reparación	<input type="checkbox"/> Otro
Otro (Especificar)	Banco (Equipo de ventilación)			

INSTRUMENTAL DE MEDICIÓN

Identificación sonómetro					
Marca	Larson Davis	Modelo	LxT1	N° serie	5526
Fecha de emisión Certificado de Calibración			17.01.2018		
Número de Certificado de Calibración			2018000669		
Identificación calibrador					
Marca	Larson Davis	Modelo	CAL200	N° serie	15291
Fecha de emisión Certificado de Calibración			21.12.2017		
Número de Certificado de Calibración			2017013480		
Ponderación en frecuencia	Filtro A		Ponderación temporal	Slow	
Verificación de Calibración en Terreno	<input checked="" type="checkbox"/> Si		<input type="checkbox"/> No		
Se deberá adjuntar Certificado de Calibración Periódica Vigente para ambos instrumentos.					

REPORTE TÉCNICO DECRETO SUPREMO N°38/11 DEL MINISTERIO DEL MEDIO AMBIENTE

Establece Norma de Emisión de Ruidos Generados por Fuentes que Indica

FICHA DE INFORMACIÓN DE MEDICIÓN DE RUIDO

IDENTIFICACIÓN DEL RECEPTOR

Receptor N°1	María Elena Pezoa Solís		
Rut	8.537.159-2		
Calle	Padre Mariano		
Número	87, depto. 608		
Comuna	Providencia		
Fono	977086514		
E-Mail	me.cprsig@gmail.com		
Datum	WGS84	Huso	19 S
Coordenada Norte	6300319.84 m	Coordenada Este	349775.12 m
Nombre de Zona de emplazamiento	UpEC, Uso preferentemente Equipamiento Comercial		
N° de Certificado de Informaciones Previas*			
Zonificación DS N° 38/11 MMA	<input type="checkbox"/> I	<input type="checkbox"/> II	<input checked="" type="checkbox"/> III
	<input type="checkbox"/> IV	<input type="checkbox"/> Rural	

* Adjuntar Certificado de Informaciones Previas (Si corresponde, según consideraciones de Art. 8°, D.S. N° 38/11 MMA)

CONDICIONES DE MEDICIÓN

Fecha medición	07.12.18		
Hora inicio medición	00:50 hrs		
Hora término medición	01:10 hrs		
Periodo de medición	<input type="checkbox"/> 7:00 a 21:00 h	<input checked="" type="checkbox"/> 21:00 a 7:00 h	
Lugar de medición	<input type="checkbox"/> Medición Interna	<input checked="" type="checkbox"/> Medición Externa	
Descripción del lugar de medición	Balcón		
Condiciones de ventana (en caso de medición interna)	<input type="checkbox"/> Ventana Abierta	<input type="checkbox"/> Ventana Cerrada	
Identificación ruido de fondo	Tránsito moderado		
Temperatura [°C]	17	Humedad [%]	70
		Velocidad de viento [m/s]	2,7

Nombre y firma Inspector Ambiental (IA)	Daniel Arenas González Ingeniero de Ejecución en Sonido	
Entidad Técnica de Fiscalización Ambiental	Municipalidad de Providencia	

Nota:

- Se deberá imprimir y completar esta página para cada receptor evaluado.
- Se podrán incluir fotografías del punto donde se ubique el sonómetro para la realización de la medición.
- Los datos de Temperatura, Humedad Relativa y Velocidad de viento, corresponderá para mediciones realizadas en el exterior.

FICHA DE GEORREFERENCIACIÓN DE MEDICIÓN DE RUIDO

Croquis

Imagen Satelital

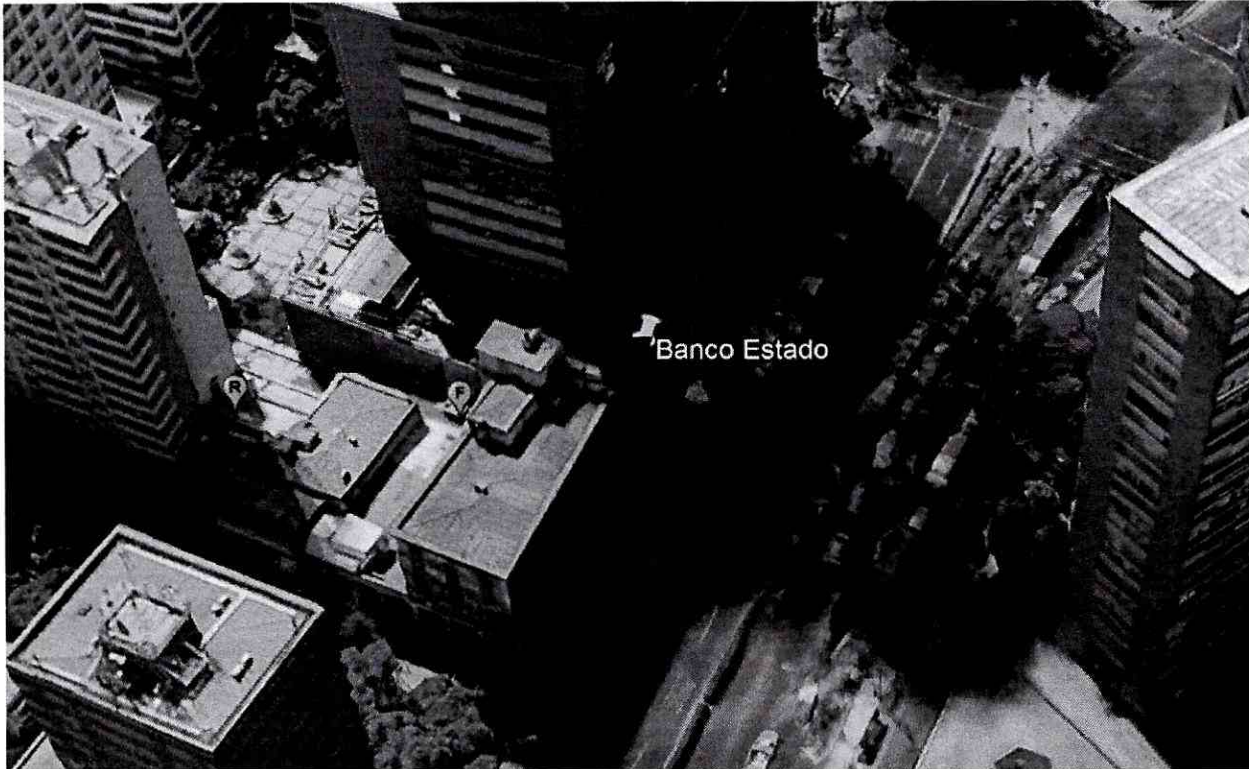

Origen de la imagen Satelital	Google Earth
Escala de la imagen Satelital	

LEYENDA DE CROQUIS O IMAGEN UTILIZADA

Datum		WGS84		Huso		19 S	
Fuentes				Receptores			
Símbolo	Nombre	Coordenadas		Símbolo	Nombre	Coordenadas	
F	Equipo de climatización	N	6300297.45 m	R	Reclamante	N	6300319.84 m
		E	349804.52 m			E	349775.12 m
		N				N	
		E				E	
		N				N	
		E				E	
		N				N	
		E				E	

Se podrán adjuntar fotografías, considerando como máximo una (1) por fuente y dos (2) por lugar de medición.

REPORTE TÉCNICO DECRETO SUPREMO N°38/11 DEL MINISTERIO DEL MEDIO AMBIENTE

Establece Norma de Emisión de Ruidos Generados por Fuentes que Indica

FICHA DE MEDICIÓN DE NIVELES DE RUIDO

REGISTRO DE MEDICIÓN DE RUIDO DE FUENTE EMISORA

Identificación Receptor N°	1
<input type="checkbox"/> Medición Interna (tres puntos)	<input checked="" type="checkbox"/> Medición externa (un punto)

	NPSeq	NPSmin	NPSmáx
Punto 1	61	59,9	62,8
	64	61,4	69,3
	61,4	59,7	63,2
Punto 2			
Punto 3			

REGISTRO DE RUIDO DE FONDO

Ruido de fondo afecta la medición	<input checked="" type="checkbox"/> Sí	<input type="checkbox"/> No
Fecha:	31.10.18	Hora: 00:30 hrs

	5'	10'	15'	20'	25'
NPSeq	54	54			

Observaciones:

FICHA DE EVALUACIÓN DE NIVELES DE RUIDO

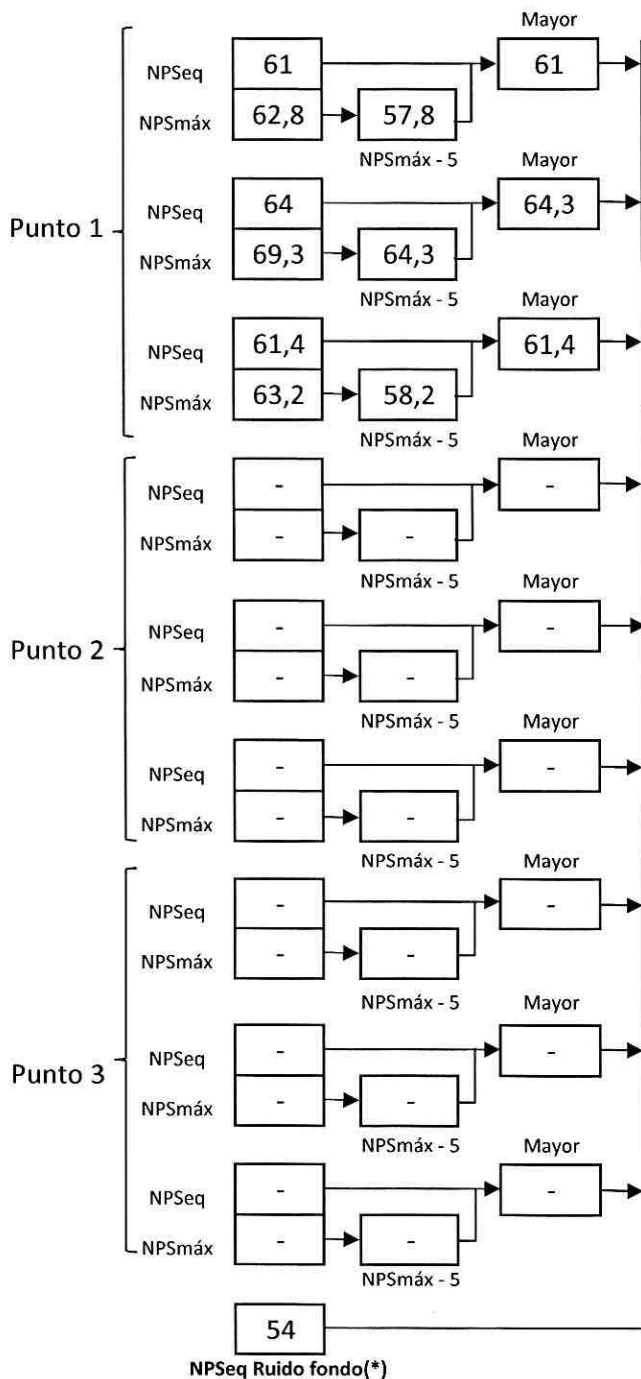

Información del Receptor	
Identificación del Receptor N°	1
Indicar Condiciones	
Medición	Exterior
Ventana	No Aplica
Modelación ISO 9613	
No	

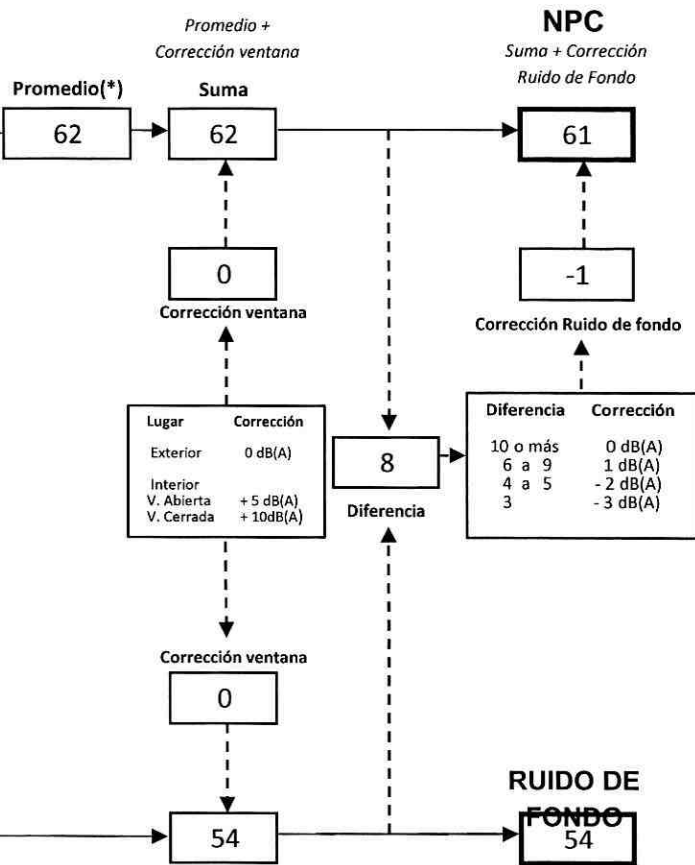

(*) Aproximar a números enteros

REPORTE TÉCNICO DECRETO SUPREMO N°38/11 DEL MINISTERIO DEL MEDIO AMBIENTE

Establece Norma de Emisión de Ruidos Generados por Fuentes que Indica

FICHA DE EVALUACIÓN DE NIVELES DE RUIDO

TABLA DE EVALUACIÓN

Receptor N°	NPC [dBA]	Ruido de Fondo [dBA]	Zona DS N°38	Periodo (Diurno/Nocturno)	Límite [dBA]	Estado (Supera/No Supera)
1	61	54	III	Nocturno	50	Supera
			Seleccione	Seleccione	-	-
			Seleccione	Seleccione	-	-
			Seleccione	Seleccione	-	-
			Seleccione	Seleccione	-	-
			Seleccione	Seleccione	-	-
			Seleccione	Seleccione	-	-
			Seleccione	Seleccione	-	-
			Seleccione	Seleccione	-	-
			Seleccione	Seleccione	-	-
			Seleccione	Seleccione	-	-

OBSERVACIONES

ANEXOS

N°	Descripción

RESPONSABLE DEL REPORTE (Llenar sólo ETFA)

Fecha del reporte	
Nombre Representante Legal	
Firma Representante Legal	

Calibration Certificate

Certificate Number 2018000669

Customer:

Sistemas De Instrumentacion
Concha Y Toro NO 65
Santiago-Centro
Santiago, , Chile

Model Number LxT1
Serial Number 0005526
Test Results Pass
Initial Condition As Manufactured
Description SoundTrack LxT Class 1
Class 1 Sound Level Meter
Firmware Revision: 2.302

Procedure Number D0001.8384
Technician Ron Harris
Calibration Date 17 Jan 2018
Calibration Due 17 Jan 2020
Temperature 23.33 °C ± 0.25 °C
Humidity 50.7 %RH ± 2.0 %RH
Static Pressure 87.08 kPa ± 0.13 kPa

Evaluation Method

Tested with:

Larson Davis PRMLxT1. S/N 046806
PCB 377B02. S/N 177005
Larson Davis CAL200. S/N 9079
Larson Davis CAL291. S/N 0203

Data reported in dB re 20 µPa.

Compliance Standards

Compliant to Manufacturer Specifications and the following standards when combined with Calibration Certificate from procedure D0001.8378:

IEC 60651:2001 Type 1	ANSI S1.4-2014 Class 1
IEC 60804:2000 Type 1	ANSI S1.4 (R2006) Type 1
IEC 61252:2002	ANSI S1.11 (R2009) Class 1
IEC 61260:2001 Class 1	ANSI S1.25 (R2007)
IEC 61672:2013 Class 1	ANSI S1.43 (R2007) Type 1

Issuing lab certifies that the instrument described above meets or exceeds all specifications as stated in the referenced procedure (unless otherwise noted). It has been calibrated using measurement standards traceable to the International System of Units (SI) through the National Institute of Standards and Technology (NIST), or other national measurement institutes, and meets the requirements of ISO/IEC 17025:2005.

Test points marked with a ‡ in the uncertainties column do not fall within this laboratory's scope of accreditation.

The quality system is registered to ISO 9001:2008.

This calibration is a direct comparison of the unit under test to the listed reference standards and did not involve any sampling plans to complete. No allowance has been made for the instability of the test device due to use, time, etc. Such allowances would be made by the customer as needed.

The uncertainties were computed in accordance with the ISO Guide to the Expression of Uncertainty in Measurement (GUM). A coverage factor of approximately 2 sigma (k=2) has been applied to the standard uncertainty to express the expanded uncertainty at approximately 95% confidence level.

This report may not be reproduced, except in full, unless permission for the publication of an approved abstract is obtained in writing from the organization issuing this report.

Correction data from Larson Davis LxT Manual for SoundTrack LxT & SoundExpert Lxt, I770.01 Rev J Supporting Firmware Version 2.301, 2015-04-30

Larson Davis, a division of PCB Piezotronics, Inc
1681 West 820 North
Provo, UT 84601, United States
716-684-0001



Certificate Number 201800669

For 1/4" microphones, the Larson Davis ADP024 1/4" to 1/2" adaptor is used with the calibrators and the Larson Davis ADP043 1/4" to 1/2" adaptor is used with the preamplifier.

Calibration Check Frequency: 1000 Hz; Reference Sound Pressure Level: 114 dB re 20 µPa

Periodic tests were performed in accordance with precedures from IEC 61672-3:2013 / ANSI/ASA S1.4-2014/Part3.

Pattern approval for IEC 61672-1:2013 / ANSI/ASA S1 4-2014/Part 1 successfully completed by Physikalisch-Technische Bundesanstalt (PTB) on 2007-10-09 reference number PTB-1.72-4034218.

The sound level meter submitted for testing successfully completed the periodic tests of IEC 61672-3:2013 / ANSI/ASA S1.4-2014/Part 3, for the environmental conditions under which the tests were performed. As evidence was publicly available, from an independent testing organization responsible for approving the results of pattern-evaluation tests performed in accordance with IEC 61672-2:2013 / ANSI/ASA S1.4-2014/Part 2, to demonstrate that the model of sound level meter fully conformed to the class 1 specifications in IEC 61672-1:2013 / ANSI/ASA S1.4-2014/Part 1; the sound level meter submitted for testing conforms to the class 1 specifications in IEC 61672-1:2013 / ANSI/ASA S1.4-2014/Part 1.

Standards Used			
Description	Cal Date	Cal Due	Cal Standard
SRS DS360 Ultra Low Distortion Generator	2017-06-23	2018-06-23	006311
Hart Scientific 2626-S Humidity/Temperature Sensor	2017-06-11	2018-06-11	006943
Larson Davis CAL200 Acoustic Calibrator	2017-07-25	2018-07-25	007027
Larson Davis Model 831	2017-03-01	2018-03-01	007182
PCB 377A13 1/2 inch Prepolarized Pressure Microphone	2017-03-08	2018-03-08	007185
Larson Davis CAL291 Residual Intensity Calibrator	2017-09-19	2018-09-19	007287

Acoustic Calibration

Measured according to IEC 61672-3:2013 10 and ANSI S1.4-2014 Part 3: 10

Measurement	Test Result [dB]	Lower Limit [dB]	Upper Limit [dB]	Expanded Uncertainty [dB]	Result
1000 Hz	114.00	113.80	114.20	0.14	Pass

Acoustic Signal Tests, C-weighting

Measured according to IEC 61672-3:2013 12 and ANSI S1.4-2014 Part 3: 12 using a comparison coupler with Unit Under Test (UUT) and reference SLM using slow time-weighted sound level for compliance to IEC 61672-1:2013 5.5; ANSI S1.4-2014 Part 1: 5.5

Frequency [Hz]	Test Result [dB]	Expected [dB]	Lower Limit [dB]	Upper Limit [dB]	Expanded Uncertainty [dB]	Result
125	-0.22	-0.20	-1.20	0.80	0.23	Pass
1000	0.18	0.00	-0.70	0.70	0.23	Pass
8000	-2.61	-3.00	-5.50	-1.50	0.32	Pass

-- End of measurement results--

Self-generated Noise

Measured according to IEC 61672-3:2013 11.1 and ANSI S1.4-2014 Part 3: 11.1

Measurement	Test Result [dB]
A-weighted	40.63

-- End of measurement results--

Larson Davis, a division of PCB Piezotronics, Inc
1681 West 820 North
Provo, UT 84601, United States
716-684-0001



-- End of Report--

Signatory: Ron Harris

Larson Davis, a division of PCB Piezotronics, Inc
1681 West 820 North
Provo, UT 84601, United States
716-684-0001



LARSON DAVIS
A PCB PIEZOTRONICS DIV.

Calibration Certificate

Certificate Number 2017013480

Customer:

Sistemas De Instrumentacion

Concha Y Toro NO 65

Santiago-Centro

Santiago, Chile

Model Number CAL200

Serial Number 15291

Test Results Pass

Initial Condition As Manufactured

Description Larson Davis CAL200 Acoustic Calibrator

Procedure Number D0001.8386

Technician Scott Montgomery

Calibration Date 21 Dec 2017

Calibration Due 21 Dec 2019

Temperature 22 °C ± 0.3 °C

Humidity 32 %RH ± 3 %RH

Static Pressure 101.3 kPa ± 1 kPa

Evaluation Method The data is acquired by the insert voltage calibration method using the reference microphone's open circuit sensitivity. Data reported in dB re 20 µPa.

Compliance Standards Compliant to Manufacturer Specifications per D0001.8190 and the following standards:
IEC 60942:2003 ANSI S1.40-2006

Issuing lab certifies that the instrument described above meets or exceeds all specifications as stated in the referenced procedure (unless otherwise noted). It has been calibrated using measurement standards traceable to the SI through the National Institute of Standards and Technology (NIST), or other national measurement institutes, and meets the requirements of ISO/IEC 17025:2005. Test points marked with a ‡ in the uncertainties column do not fall within this laboratory's scope of accreditation.

The quality system is registered to ISO 9001:2008.

This calibration is a direct comparison of the unit under test to the listed reference standards and did not involve any sampling plans to complete. No allowance has been made for the instability of the test device due to use, time, etc. Such allowances would be made by the customer as needed.

The uncertainties were computed in accordance with the ISO Guide to the Expression of Uncertainty in Measurement (GUM). A coverage factor of approximately 2 sigma (k=2) has been applied to the standard uncertainty to express the expanded uncertainty at approximately 95% confidence level.

This report may not be reproduced, except in full, unless permission for the publication of an approved abstract is obtained in writing from the organization issuing this report.

Standards Used

Description	Cal Date	Cal Due	Cal Standard
Agilent 34401A DMM	09/06/2017	09/06/2018	001021
Larson Davis Model 2900 Real Time Analyzer	04/10/2017	04/10/2018	001051
Microphone Calibration System	08/08/2017	08/08/2018	005446
1/2" Preamplifier	10/05/2017	10/05/2018	006506
Larson Davis 1/2" Preamplifier 7-pin LEMO	08/08/2017	08/08/2018	006507
1/2 inch Microphone - RI - 200V	04/24/2017	04/24/2018	006510
Pressure Transducer	06/01/2017	06/01/2018	007310

Larson Davis, a division of PCB Piezotronics, Inc
1681 West 820 North
Provo, UT 84601, United States
716-684-0001



LARSON DAVIS
A PCB PIEZOTRONICS DIV.

Output Level

Nominal Level [dB]	Pressure [kPa]	Test Result [dB]	Lower limit [dB]	Upper limit [dB]	Expanded Uncertainty [dB]	Result
114	101.3	114.00	113.80	114.20	0.13	Pass
94	101.3	94.01	93.80	94.20	0.14	Pass

-- End of measurement results--

Frequency

Nominal Level [dB]	Pressure [kPa]	Test Result [Hz]	Lower limit [Hz]	Upper limit [Hz]	Expanded Uncertainty [Hz]	Result
94	101.3	1,000.10	990.00	1,010.00	0.20	Pass
114	101.3	1,000.09	990.00	1,010.00	0.20	Pass

-- End of measurement results--

Total Harmonic Distortion + Noise (THD+N)

Nominal Level [dB]	Pressure [kPa]	Test Result [%]	Lower limit [%]	Upper limit [%]	Expanded Uncertainty [%]	Result
94	101.3	0.42	0.00	2.00	0.25	Pass
114	101.3	0.38	0.00	2.00	0.25	Pass

-- End of measurement results--

Level Change Over Pressure

Tested at: 114 dB, 23 °C, 28 %RH

Nominal Pressure [kPa]	Pressure [kPa]	Test Result [dB]	Lower limit [dB]	Upper limit [dB]	Expanded Uncertainty [dB]	Result
101.3	101.1	0.00	-0.30	0.30	0.04 ‡	Pass
92.0	92.0	0.00	-0.30	0.30	0.04 ‡	Pass
108.0	108.0	-0.02	-0.30	0.30	0.04 ‡	Pass
83.0	83.2	-0.01	-0.30	0.30	0.04 ‡	Pass
74.0	74.1	-0.06	-0.30	0.30	0.04 ‡	Pass
65.0	65.1	-0.14	-0.30	0.30	0.04 ‡	Pass

-- End of measurement results--

Frequency Change Over Pressure

Tested at: 114 dB, 23 °C, 28 %RH

Nominal Pressure [kPa]	Pressure [kPa]	Test Result [Hz]	Lower limit [Hz]	Upper limit [Hz]	Expanded Uncertainty [Hz]	Result
108.0	108.0	0.00	-10.00	10.00	0.20 ‡	Pass
101.3	101.1	0.00	-10.00	10.00	0.20 ‡	Pass
92.0	92.0	0.00	-10.00	10.00	0.20 ‡	Pass
83.0	83.2	-0.01	-10.00	10.00	0.20 ‡	Pass
74.0	74.1	-0.01	-10.00	10.00	0.20 ‡	Pass
65.0	65.1	-0.02	-10.00	10.00	0.20 ‡	Pass

-- End of measurement results--

Larson Davis, a division of PCB Piezotronics, Inc
 1681 West 820 North
 Provo, UT 84601, United States
 716-684-0001



Total Harmonic Distortion + Noise (THD+N) Over Pressure

Tested at: 114 dB, 23 °C, 28 %RH

Nominal Pressure [kPa]	Pressure [kPa]	Test Result [%]	Lower limit [%]	Upper limit [%]	Expanded Uncertainty [%]	Result
108.0	108.0	0.39	0.00	2.00	0.25 ‡	Pass
101.3	101.1	0.38	0.00	2.00	0.25 ‡	Pass
92.0	92.0	0.37	0.00	2.00	0.25 ‡	Pass
83.0	83.2	0.36	0.00	2.00	0.25 ‡	Pass
74.0	74.1	0.36	0.00	2.00	0.25 ‡	Pass
65.0	65.1	0.36	0.00	2.00	0.25 ‡	Pass

-- End of measurement results--

Signatory: Scott Montgomery

Larson Davis, a division of PCB Piezotronics, Inc
 1681 West 820 North
 Provo, UT 84601, United States
 716-684-0001





Model CAL200 Relative SPL vs. Temperature

Larson Davis Model CAL200 Serial Number: 15291

Model CAL200 Relative SPL vs. Temperature at 50% RH.

A 2559 Mic (SN: 2995) with a PRM902 Preamp (SN: 5726), station 19 was used to check the levels.

Test Date: 05 Dec 2017 17:42:11

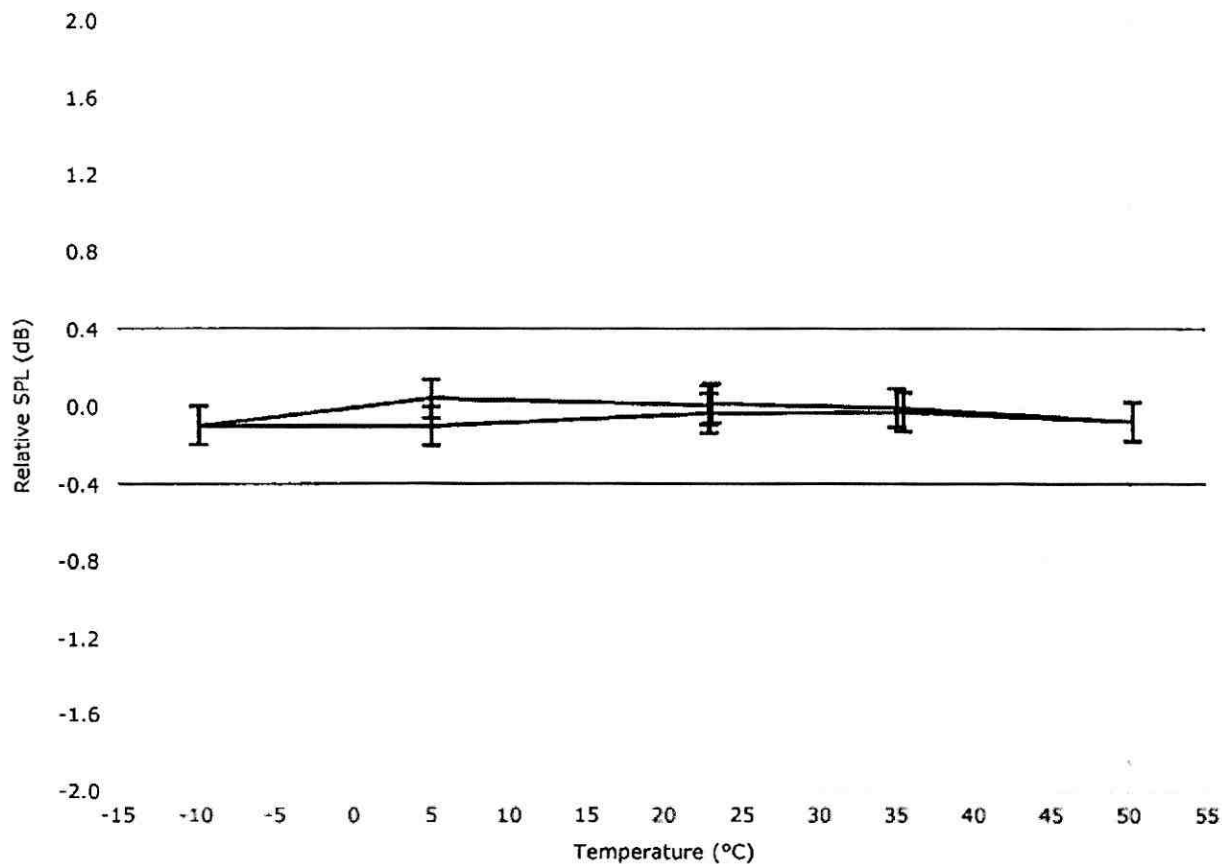

0.1dB expanded uncertainty at ~95% confidence level (k=2)

Sequence File: CAL200.SEQ

Test Location: Larson Davis, a division of PCB Piezotronics, Inc.
1681 West 820 North, Provo, Utah 84601
Tel: 716 684-0001 www.LarsonDavis.com



Model CAL200 Relative Frequency vs. Temperature

Larson Davis Model CAL200 Serial Number: 15291

Model CAL200 Relative Frequency vs. Temperature at 50% RH.
A 2559 Mic (SN: 2995) with a PRM902 Preamp (SN: 5726), station 19 was used to check the levels.

Test Date: 05 Dec 2017 17:42:11

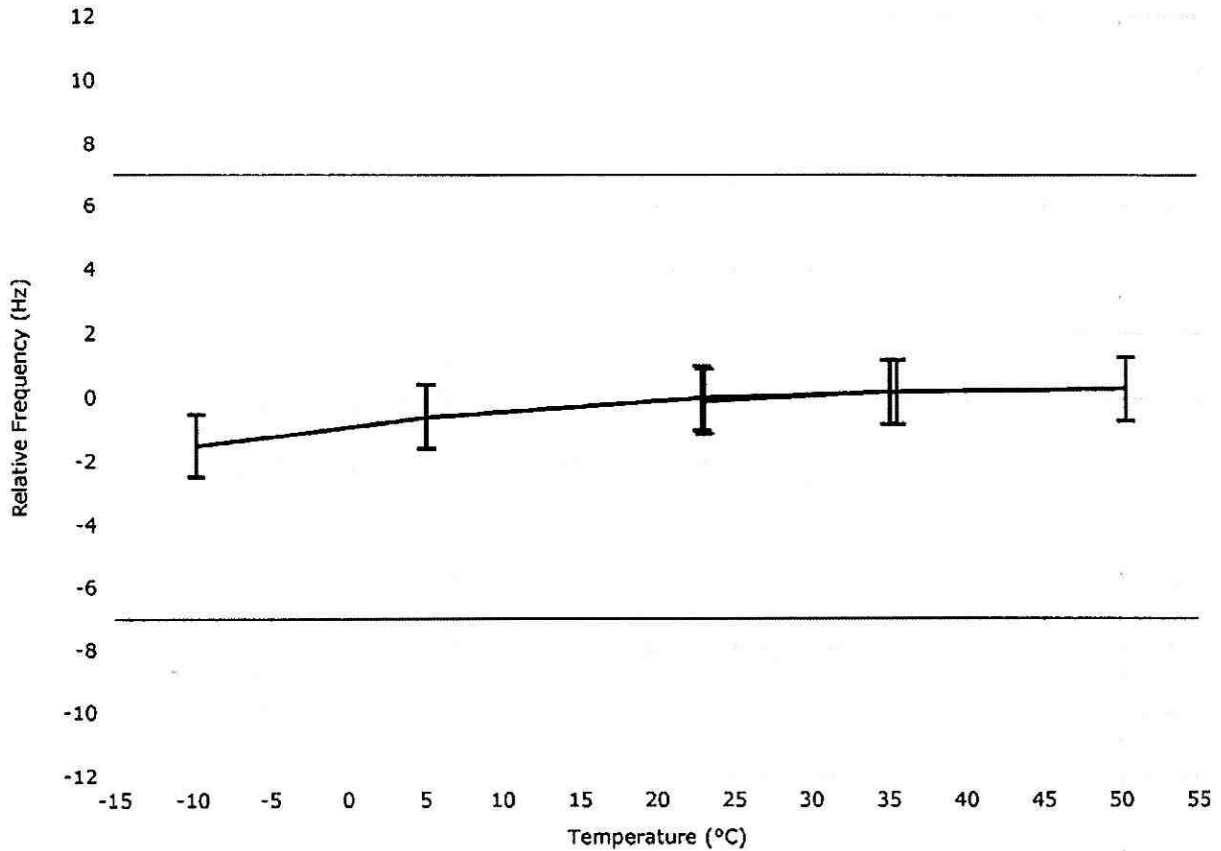

1.0 Hz expanded uncertainty at ~95% confidence level (k=2)

Sequence File: CAL200.SEQ

Test Location: Larson Davis, a division of PCB Piezotronics, Inc.
1681 West 820 North, Provo, Utah 84601
Tel: 716 684-0001 www.LarsonDavis.com