

**REPORTE TÉCNICO DECRETO SUPREMO N°38/11 DEL MINISTERIO DEL MEDIO AMBIENTE**

Establece Norma de Emisión de Ruidos Generados por Fuentes que Indica

**FICHA DE INFORMACIÓN DE MEDICIÓN DE RUIDO**

**IDENTIFICACIÓN DE LA FUENTE EMISORA DE RUIDO**

Nombre o razón social	Comercial Successo Limitada		
RUT	79.605.490-5		
Dirección	Almirante Pastene 92 - 118		
Comuna	Providencia		
Nombre de Zona de emplazamiento (según IPT vigente)	UpEC, Uso preferentemente Equipamiento Comercial		
Datum	WGS84	Huso	19S
Coordenada Norte	6300125.09 m	Coordenada Este	349385.13 m

**CARACTERIZACIÓN DE LA FUENTE EMISORA DE RUIDO**

Actividad Productiva	<input type="checkbox"/> Industrial	<input type="checkbox"/> Agrícola	<input type="checkbox"/> Extracción	<input type="checkbox"/> Otro
Actividad Comercial	<input type="checkbox"/> Restaurant	<input type="checkbox"/> Taller Mecánico	<input type="checkbox"/> Local Comercial	<input type="checkbox"/> Otro
Actividad Esparcimiento	<input type="checkbox"/> Discoteca	<input type="checkbox"/> Recinto Deportivo	<input type="checkbox"/> Cultura	<input type="checkbox"/> Otro
Actividad de Servicio	<input type="checkbox"/> Religioso	<input type="checkbox"/> Salud	<input type="checkbox"/> Comunitario	<input type="checkbox"/> Otro
Infraestructura Transporte	<input type="checkbox"/> Terminal	<input type="checkbox"/> Taller de Transporte	<input type="checkbox"/> Estación Intermedia	<input type="checkbox"/> Otro
Infraestructura Sanitaria	<input type="checkbox"/> Planta de Tratamiento	<input type="checkbox"/> Relleno Sanitario	<input type="checkbox"/> Instalación de Distribución	<input type="checkbox"/> Otro
Infraestructura Energética	<input type="checkbox"/> Generadora	<input type="checkbox"/> Distribución Eléctrica	<input type="checkbox"/> Comunicaciones	<input type="checkbox"/> Otro
Faena Constructiva	<input checked="" type="checkbox"/> Construcción	<input type="checkbox"/> Demolición	<input type="checkbox"/> Reparación	<input type="checkbox"/> Otro
Otro (Especificar)				

**INSTRUMENTAL DE MEDICIÓN**

Identificación sonómetro					
Marca	Larson Davis	Modelo	LxT1	N° serie	5526
Fecha de emisión Certificado de Calibración			17.01.2018		
Número de Certificado de Calibración			2018000669		
Identificación calibrador					
Marca	Larson Davis	Modelo	CAL200	N° serie	15291
Fecha de emisión Certificado de Calibración			21.12.2017		
Número de Certificado de Calibración			2017013480		
Ponderación en frecuencia	Filtro A		Ponderación temporal	Slow	
Verificación de Calibración en Terreno	<input checked="" type="checkbox"/> Si		<input type="checkbox"/> No		
Se deberá adjuntar Certificado de Calibración Periódica Vigente para ambos instrumentos.					

**REPORTE TÉCNICO DECRETO SUPREMO N°38/11 DEL MINISTERIO DEL MEDIO AMBIENTE**

Establece Norma de Emisión de Ruidos Generados por Fuentes que Indica

**FICHA DE INFORMACIÓN DE MEDICIÓN DE RUIDO**

**IDENTIFICACIÓN DEL RECEPTOR**

Receptor N°1	José Díaz Del Río			
Rut	4.773.804-0			
Calle	Manuel Montt			
Número	051, depto. 604			
Comuna	Providencia			
Fono	993384136			
E-Mail	jdiaz@onceonce.cl			
Datum	WGS84	Huso	19 S	
Coordenada Norte	6300091.83 m	Coordenada Este	349340.34 m	
Nombre de Zona de emplazamiento	UpEC, Uso preferentemente Equipamiento Comercial			
N° de Certificado de Informaciones Previas*				
Zonificación DS N° 38/11 MMA	<input type="checkbox"/> I	<input type="checkbox"/> II	<input checked="" type="checkbox"/> III	<input type="checkbox"/> IV <input type="checkbox"/> Rural

\* Adjuntar Certificado de Informaciones Previas (Si corresponde, según consideraciones de Art. 8°, D.S. N° 38/11 MMA)

**CONDICIONES DE MEDICIÓN**

Fecha medición	20.03.19			
Hora inicio medición	14:50 hrs			
Hora término medición	15:42 hrs			
Periodo de medición	<input checked="" type="checkbox"/> 7:00 a 21:00 h	<input type="checkbox"/> 21:00 a 7:00 h		
Lugar de medición	<input checked="" type="checkbox"/> Medición Interna	<input type="checkbox"/> Medición Externa		
Descripción del lugar de medición	Habitación de reclamante			
Condiciones de ventana (en caso de medición interna)	<input checked="" type="checkbox"/> Ventana Abierta	<input type="checkbox"/> Ventana Cerrada		
Identificación ruido de fondo	Tránsito leve			
Temperatura [°C]		Humedad [%]	Velocidad de viento [m/s]	

Nombre y firma Inspector Ambiental (IA)	Daniel Arenas González Ingeniero de Ejecución en Sonido	
Entidad Técnica de Fiscalización Ambiental	Municipalidad de Providencia	

**Nota:**

- Se deberá imprimir y completar esta página para cada receptor evaluado.
- Se podrán incluir fotografías del punto donde se ubique el sonómetro para la realización de la medición.
- Los datos de Temperatura, Humedad Relativa y Velocidad de viento, corresponderá para mediciones realizadas en el exterior.

**FICHA DE GEORREFERENCIACIÓN DE MEDICIÓN DE RUIDO**

Croquis

Imagen Satelital

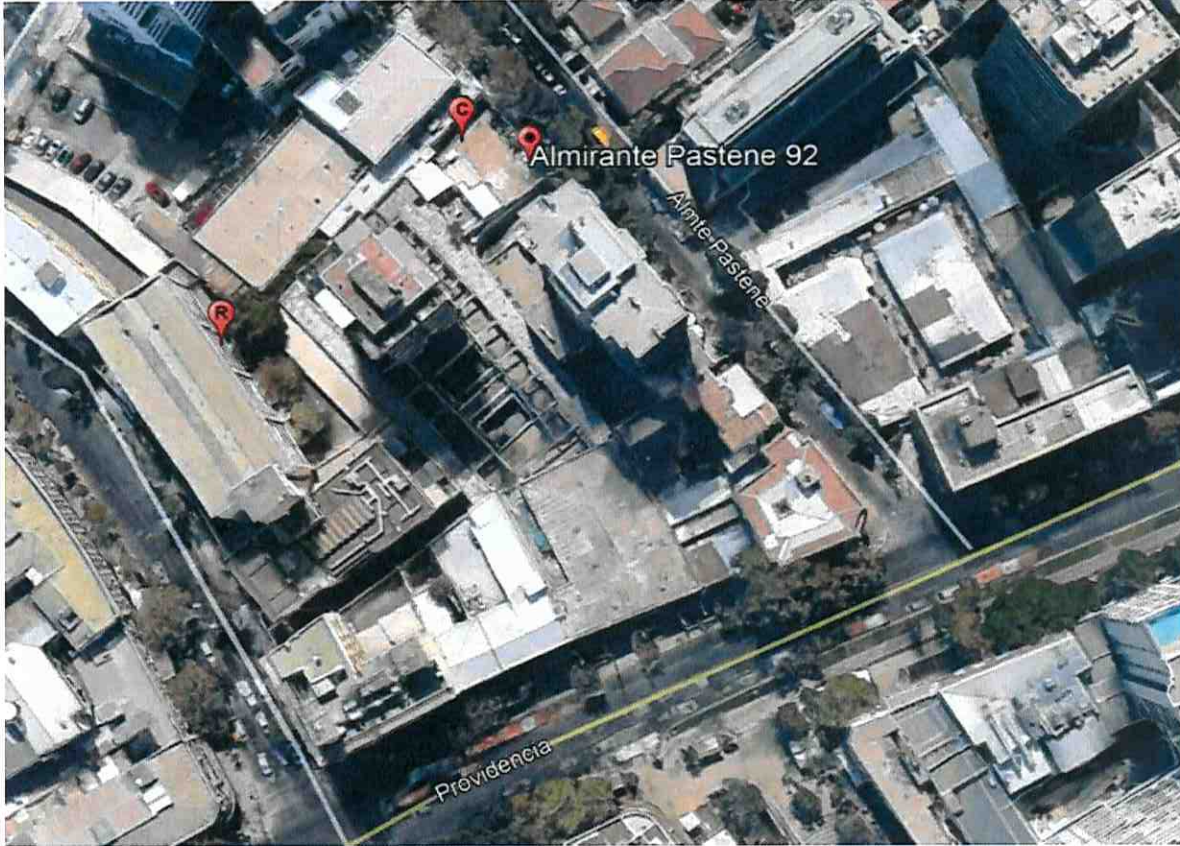

Origen de la imagen Satelital

Google Earth

Escala de la imagen Satelital

**LEYENDA DE CROQUIS O IMAGEN UTILIZADA**

Datum		WGS84		Huso		19 S	
Fuentes				Receptores			
Símbolo	Nombre	Coordenadas		Símbolo	Nombre	Coordenadas	
C	Construcción	N	6300125.09 m	R	Reclamante (Punto de medición)	N	6300091.83 m
		E	349385.13 m			E	349340.34 m

*Se podrán adjuntar fotografías, considerando como máximo una (1) por fuente y dos (2) por lugar de medición.*

**FICHA DE MEDICIÓN DE NIVELES DE RUIDO**

**REGISTRO DE MEDICIÓN DE RUIDO DE FUENTE EMISORA**

Identificación Receptor N°	1
<input checked="" type="checkbox"/> Medición Interna (tres puntos)	<input type="checkbox"/> Medición externa (un punto)

	NPSeq	NPSmin	NPSmáx
Punto 1	67,2	65	71,7
	66,7	62,1	77,6
	68	62,5	71,5
Punto 2	68	64,9	81,6
	67,8	65,8	70,7
	66,4	65	70,1
Punto 3	67,1	63,7	72,9
	62,5	57,9	81,9
	66,2	63	81,1

**REGISTRO DE RUIDO DE FONDO**

Ruido de fondo afecta la medición	<input type="checkbox"/> Si	<input checked="" type="checkbox"/> No
Fecha:	20.03.19	Hora: 10:30 hrs

	5'	10'	15'	20'	25'
NPSeq	51	48	49		

**Observaciones:**

**FICHA DE EVALUACIÓN DE NIVELES DE RUIDO**

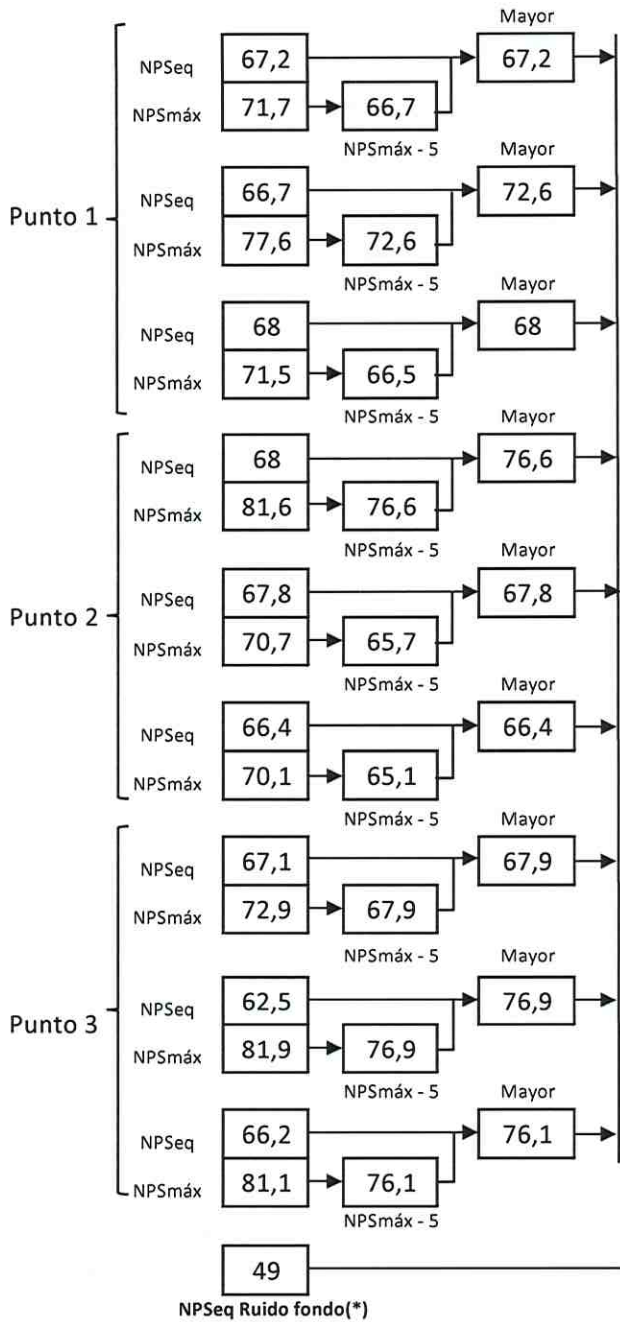

Información del Receptor	
Identificación del Receptor N°	1
Indicar Condiciones	
Medición	Interior
Ventana	Abierta
Modelación ISO 9613	
No	

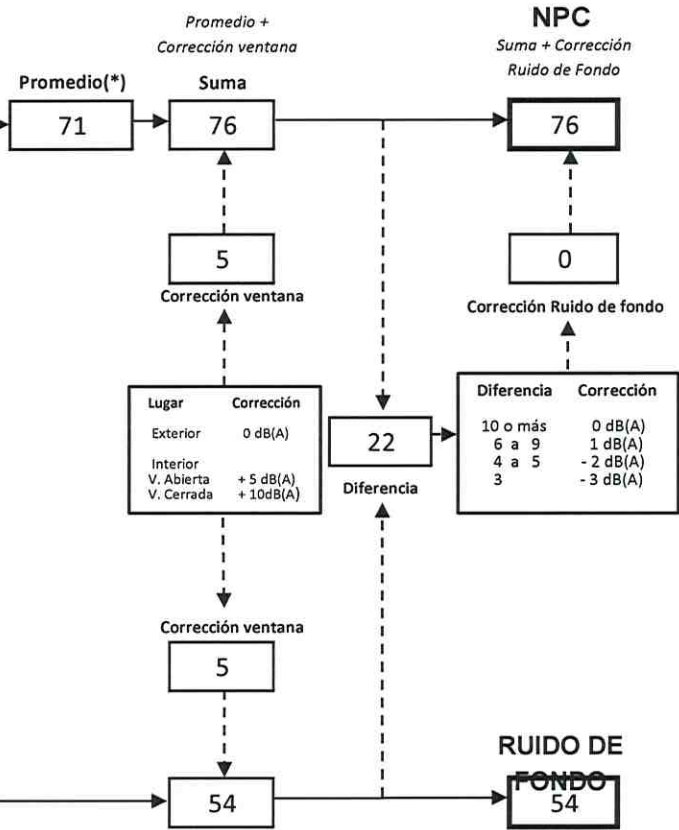

(\*) Aproximar a números enteros

**REPORTE TÉCNICO DECRETO SUPREMO N°38/11 DEL MINISTERIO DEL MEDIO AMBIENTE**  
 Establece Norma de Emisión de Ruidos Generados por Fuentes que Indica

**FICHA DE EVALUACIÓN DE NIVELES DE RUIDO**

**TABLA DE EVALUACIÓN**

Receptor N°	NPC [dBA]	Ruido de Fondo [dBA]	Zona DS N°38	Periodo (Diurno/Nocturno)	Límite [dBA]	Estado (Supera/No Supera)
1	76	54	III	Diurno	65	Supera
			Seleccione	Seleccione	-	-
			Seleccione	Seleccione	-	-
			Seleccione	Seleccione	-	-
			Seleccione	Seleccione	-	-
			Seleccione	Seleccione	-	-
			Seleccione	Seleccione	-	-
			Seleccione	Seleccione	-	-
			Seleccione	Seleccione	-	-
			Seleccione	Seleccione	-	-

**OBSERVACIONES**

Fuentes de ruido: Retroexcavadora, Camión tolva, Caída de rocas al cambiión tolva, sirenas de retroceso

El reclamante señala que el ruido es mucho mayor cuando se encuentra la perforadora operativa, sin embargo, esto no se pudo constatar

Otro reclamantes:

José Eduardo Sales Goncalves (Adm) - Mónica Núñez Navarrete (Pdta. Comité) , dpto. 503, fono: 222355029  
 976495881

**ANEXOS**

N°	Descripción

**RESPONSABLE DEL REPORTE (Llenar sólo ETF)**

Fecha del reporte	
Nombre Representante Legal	
Firma Representante Legal	

# Calibration Certificate

Certificate Number 2018000669

Customer:  
Sistemas De Instrumentacion  
Concha Y Toro NO 65  
Santiago-Centro  
Santiago, Chile

Model Number LxT1  
Serial Number 0005526  
Test Results Pass

Initial Condition As Manufactured

Description SoundTrack LxT Class 1  
Class 1 Sound Level Meter  
Firmware Revision: 2.302

Procedure Number D0001.8384  
Technician Ron Harris  
Calibration Date 17 Jan 2018  
Calibration Due 17 Jan 2020  
Temperature 23.33 °C ± 0.25 °C  
Humidity 50.7 %RH ± 2.0 %RH  
Static Pressure 87.08 kPa ± 0.13 kPa

Evaluation Method Tested with: Data reported in dB re 20 µPa.

Larson Davis PRMLxT1, S/N 046806  
PCB 377B02, S/N 177005  
Larson Davis CAL200, S/N 9079  
Larson Davis CAL291, S/N 0203

Compliance Standards Compliant to Manufacturer Specifications and the following standards when combined with Calibration Certificate from procedure D0001.8378:

IEC 60651:2001 Type 1	ANSI S1.4-2014 Class 1
IEC 60804:2000 Type 1	ANSI S1.4 (R2006) Type 1
IEC 61252:2002	ANSI S1.11 (R2009) Class 1
IEC 61260:2001 Class 1	ANSI S1.25 (R2007)
IEC 61672:2013 Class 1	ANSI S1.43 (R2007) Type 1

Issuing lab certifies that the instrument described above meets or exceeds all specifications as stated in the referenced procedure (unless otherwise noted). It has been calibrated using measurement standards traceable to the International System of Units (SI) through the National Institute of Standards and Technology (NIST), or other national measurement institutes, and meets the requirements of ISO/IEC 17025:2005.

Test points marked with a \$ in the uncertainties column do not fall within this laboratory's scope of accreditation.

The quality system is registered to ISO 9001:2008.

This calibration is a direct comparison of the unit under test to the listed reference standards and did not involve any sampling plans to complete. No allowance has been made for the instability of the test device due to use, time, etc. Such allowances would be made by the customer as needed.

The uncertainties were computed in accordance with the ISO Guide to the Expression of Uncertainty in Measurement (GUM). A coverage factor of approximately 2 sigma (k=2) has been applied to the standard uncertainty to express the expanded uncertainty at approximately 95% confidence level.

This report may not be reproduced, except in full, unless permission for the publication of an approved abstract is obtained in writing from the organization issuing this report.

Correction data from Larson Davis LxT Manual for SoundTrack LxT & SoundExpert LxT, I770.01 Rev J Supporting Firmware Version 2.301, 2015-04-30

Larson Davis, a division of PCB Piezotronics, Inc  
1681 West 820 North  
Provo, UT 84601, United States  
716-684-0001



**LARSON DAVIS**  
A PCB PIEZOTRONICS DIV.

Certificate Number 2018000669

For 1/4" microphones, the Larson Davis ADP024 1/4" to 1/2" adaptor is used with the calibrators and the Larson Davis ADP043 1/4" to 1/2" adaptor is used with the preamplifier.

Calibration Check Frequency: 1000 Hz; Reference Sound Pressure Level: 114 dB re 20 µPa

Periodic tests were performed in accordance with procedures from IEC 61672-3:2013 / ANSI/ASA S1.4-2014/Part 3.

Pattern approval for IEC 61672-1:2013 / ANSI/ASA S1.4-2014/Part 1 successfully completed by Physikalisch-Technische Bundesanstalt (PTB) on 2007-10-09 reference number PTB-1.72-4034218.

The sound level meter submitted for testing successfully completed the periodic tests of IEC 61672-3:2013 / ANSI/ASA S1.4-2014/Part 3, for the environmental conditions under which the tests were performed. As evidence was publicly available, from an independent testing organization responsible for approving the results of pattern-evaluation tests performed in accordance with IEC 61672-2:2013 / ANSI/ASA S1.4-2014/Part 2, to demonstrate that the model of sound level meter fully conformed to the class 1 specifications in IEC 61672-1:2013 / ANSI/ASA S1.4-2014/Part 1; the sound level meter submitted for testing conforms to the class 1 specifications in IEC 61672-1:2013 / ANSI/ASA S1.4-2014/Part 1.

Standards Used			
Description	Cal Date	Cal Due	Cal Standard
SRS DS360 Ultra Low Distortion Generator	2017-06-23	2018-06-23	006311
Hart Scientific 2626-S Humidity/Temperature Sensor	2017-06-11	2018-06-11	006943
Larson Davis CAL200 Acoustic Calibrator	2017-07-25	2018-07-25	007027
Larson Davis Model 831	2017-03-01	2018-03-01	007182
PCB 377A13 1/2 inch Prepolarized Pressure Microphone	2017-03-08	2018-03-08	007185
Larson Davis CAL291 Residual Intensity Calibrator	2017-09-19	2018-09-19	007287

## Acoustic Calibration

Measured according to IEC 61672-3:2013 10 and ANSI S1.4-2014 Part 3: 10

Measurement	Test Result [dB]	Lower Limit [dB]	Upper Limit [dB]	Expanded Uncertainty [dB]	Result
1000 Hz	114.00	113.80	114.20	0.14	Pass

## Acoustic Signal Tests, C-weighting

Measured according to IEC 61672-3:2013 12 and ANSI S1.4-2014 Part 3: 12 using a comparison coupler with Unit Under Test (UUT) and reference SLM using slow time-weighted sound level for compliance to IEC 61672-1:2013 5.5; ANSI S1.4-2014 Part 1: 5.5

Frequency [Hz]	Test Result [dB]	Expected [dB]	Lower Limit [dB]	Upper Limit [dB]	Expanded Uncertainty [dB]	Result
125	-0.22	-0.20	-1.20	0.80	0.23	Pass
1000	0.18	0.00	-0.70	0.70	0.23	Pass
8000	-2.61	-3.00	-5.50	-1.50	0.32	Pass

-- End of measurement results--

## Self-generated Noise

Measured according to IEC 61672-3:2013 11.1 and ANSI S1.4-2014 Part 3: 11.1

Measurement	Test Result [dB]
A-weighted	40.63

-- End of measurement results--

Larson Davis, a division of PCB Piezotronics, Inc  
1681 West 820 North  
Provo, UT 84601, United States  
716-684-0001



**LARSON DAVIS**  
A PCB PIEZOTRONICS DIV.

# Calibration Certificate

Certificate Number 2017013480

**Customer:**  
Sistemas De Instrumentacion  
Concha Y Toro NO 65  
Santiago-Centro  
Santiago, Chile

**Model Number** CAL200  
**Serial Number** 15291  
**Test Results** Pass  
**Initial Condition** As Manufactured  
**Description** Larson Davis CAL200 Acoustic Calibrator

**Procedure Number** D0001.8386  
**Technician** Scott Montgomery  
**Calibration Date** 21 Dec 2017  
**Calibration Due** 21 Dec 2019  
**Temperature** 22 °C ± 0.3 °C  
**Humidity** 32 %RH ± 3 %RH  
**Static Pressure** 101.3 kPa ± 1 kPa

**Evaluation Method** The data is acquired by the insert voltage calibration method using the reference microphone's open circuit sensitivity. Data reported in dB re 20 µPa.

**Compliance Standards** Compliant to Manufacturer Specifications per D0001.8190 and the following standards:  
IEC 60942:2003 ANSI S1.40-2006

Issuing lab certifies that the instrument described above meets or exceeds all specifications as stated in the referenced procedure (unless otherwise noted). It has been calibrated using measurement standards traceable to the SI through the National Institute of Standards and Technology (NIST), or other national measurement institutes, and meets the requirements of ISO/IEC 17025:2005. Test points marked with a ‡ in the uncertainties column do not fall within this laboratory's scope of accreditation.

The quality system is registered to ISO 9001:2008.

This calibration is a direct comparison of the unit under test to the listed reference standards and did not involve any sampling plans to complete. No allowance has been made for the instability of the test device due to use, time, etc. Such allowances would be made by the customer as needed.

The uncertainties were computed in accordance with the ISO Guide to the Expression of Uncertainty in Measurement (GUM). A coverage factor of approximately 2 sigma (k=2) has been applied to the standard uncertainty to express the expanded uncertainty at approximately 95% confidence level.

This report may not be reproduced, except in full, unless permission for the publication of an approved abstract is obtained in writing from the organization issuing this report.

Description	Standards Used		Cal Standard
	Cal Date	Cal Due	
Agilent 34401A DMM	09/06/2017	09/06/2018	001021
Larson Davis Model 2900 Real Time Analyzer	04/10/2017	04/10/2018	001051
Microphone Calibration System	08/08/2017	08/08/2018	005446
1/2" Preamp	10/05/2017	10/05/2018	006506
Larson Davis 1/2" Preamp 7-pin LEMO	08/08/2017	08/08/2018	006507
1/2 inch Microphone - RI - 200V	04/24/2017	04/24/2018	006510
Pressure Transducer	06/01/2017	06/01/2018	007310

— End of Report—

Signatory: Ron Harris

Larson Davis, a division of PCB Piezotronics, Inc  
1681 West 820 North  
Provo, UT 84601, United States  
716-684-0001



**LARSON DAVIS**  
A PCB PIEZOTRONICS DIV.

D0001.8406 Rev B

Larson Davis, a division of PCB Piezotronics, Inc  
1681 West 820 North  
Provo, UT 84601, United States  
716-684-0001



**LARSON DAVIS**  
A PCB PIEZOTRONICS DIV.

D0001.8410 Rev A



Certificate Number 2017013480

**Output Level**

Nominal Level [dB]	Pressure [kPa]	Test Result [dB]	Lower limit [dB]	Upper limit [dB]	Expanded Uncertainty [dB]	Result
114	101.3	114.00	113.80	114.20	0.13	Pass
94	101.3	94.01	93.80	94.20	0.14	Pass

-- End of measurement results--

**Frequency**

Nominal Level [dB]	Pressure [kPa]	Test Result [Hz]	Lower limit [Hz]	Upper limit [Hz]	Expanded Uncertainty [Hz]	Result
94	101.3	1,000.10	990.00	1,010.00	0.20	Pass
114	101.3	1,000.09	990.00	1,010.00	0.20	Pass

-- End of measurement results--

**Total Harmonic Distortion + Noise (THD+N)**

Nominal Level [dB]	Pressure [kPa]	Test Result [%]	Lower limit [%]	Upper limit [%]	Expanded Uncertainty [%]	Result
94	101.3	0.42	0.00	2.00	0.25	Pass
114	101.3	0.38	0.00	2.00	0.25	Pass

-- End of measurement results--

**Level Change Over Pressure**

Tested at: 114 dB, 23 °C, 28 %RH

Nominal Pressure [kPa]	Pressure [kPa]	Test Result [dB]	Lower limit [dB]	Upper limit [dB]	Expanded Uncertainty [dB]	Result
101.3	101.1	0.00	-0.30	0.30	0.04 ‡	Pass
92.0	92.0	0.00	-0.30	0.30	0.04 ‡	Pass
108.0	108.0	-0.02	-0.30	0.30	0.04 ‡	Pass
83.0	83.2	-0.01	-0.30	0.30	0.04 ‡	Pass
74.0	74.1	-0.06	-0.30	0.30	0.04 ‡	Pass
65.0	65.1	-0.14	-0.30	0.30	0.04 ‡	Pass

-- End of measurement results--

**Frequency Change Over Pressure**

Tested at: 114 dB, 23 °C, 28 %RH

Nominal Pressure [kPa]	Pressure [kPa]	Test Result [Hz]	Lower limit [Hz]	Upper limit [Hz]	Expanded Uncertainty [Hz]	Result
108.0	108.0	0.00	-10.00	10.00	0.20 ‡	Pass
101.3	101.1	0.00	-10.00	10.00	0.20 ‡	Pass
92.0	92.0	0.00	-10.00	10.00	0.20 ‡	Pass
83.0	83.2	-0.01	-10.00	10.00	0.20 ‡	Pass
74.0	74.1	-0.01	-10.00	10.00	0.20 ‡	Pass
65.0	65.1	-0.02	-10.00	10.00	0.20 ‡	Pass

-- End of measurement results--

Certificate Number 2017013480

**Total Harmonic Distortion + Noise (THD+N) Over Pressure**

Tested at: 114 dB, 23 °C, 28 %RH

Nominal Pressure [kPa]	Pressure [kPa]	Test Result [%]	Lower limit [%]	Upper limit [%]	Expanded Uncertainty [%]	Result
108.0	108.0	0.39	0.00	2.00	0.25 ‡	Pass
101.3	101.1	0.38	0.00	2.00	0.25 ‡	Pass
92.0	92.0	0.37	0.00	2.00	0.25 ‡	Pass
83.0	83.2	0.36	0.00	2.00	0.25 ‡	Pass
74.0	74.1	0.36	0.00	2.00	0.25 ‡	Pass
65.0	65.1	0.36	0.00	2.00	0.25 ‡	Pass

-- End of measurement results--

Signatory: Scott Montgomery

Larson Davis, a division of PCB Piezotronics, Inc.  
1681 West 820 North  
Provo, UT 84601, United States  
716-684-0001



**LARSON DAVIS**  
A PCB PIEZOTRONICS DIV.

Larson Davis, a division of PCB Piezotronics, Inc.  
1681 West 820 North  
Provo, UT 84601, United States  
716-684-0001



**LARSON DAVIS**  
A PCB PIEZOTRONICS DIV.



### Model CAL200 Relative SPL vs. Temperature

Larson Davis Model CAL200 Serial Number: 15291

Model CAL200 Relative SPL vs. Temperature at 50% RH.  
A 2559 Mic (SN: 2995) with a PRM902 Preamp (SN: 5726), station 19 was used to check the levels.

Test Date: 05 Dec 2017 17:42:11

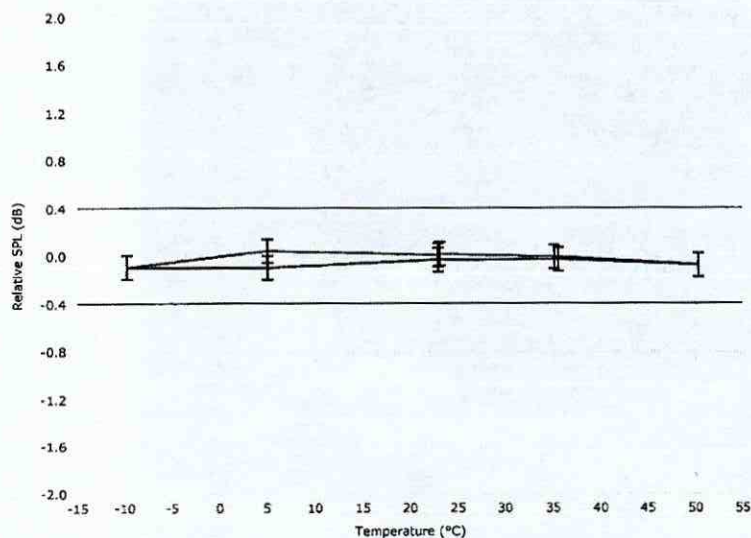

0.1dB expanded uncertainty at ~95% confidence level (k=2)

Sequence File: CAL200.SEQ

Test Location: Larson Davis, a division of PCB Piezotronics, Inc.  
1681 West 820 North, Provo, Utah 84601  
Tel: 716 684-0001 www.LarsonDavis.com



### Model CAL200 Relative Frequency vs. Temperature

Larson Davis Model CAL200 Serial Number: 15291

Model CAL200 Relative Frequency vs. Temperature at 50% RH.  
A 2559 Mic (SN: 2995) with a PRM902 Preamp (SN: 5726), station 19 was used to check the levels.

Test Date: 05 Dec 2017 17:42:11

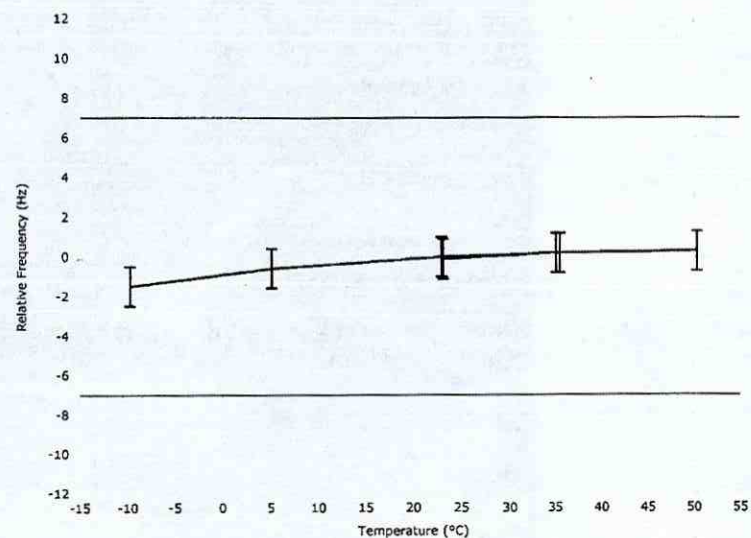

1.0 Hz expanded uncertainty at ~95% confidence level (k=2)

Sequence File: CAL200.SEQ

Test Location: Larson Davis, a division of PCB Piezotronics, Inc.  
1681 West 820 North, Provo, Utah 84601  
Tel: 716 684-0001 www.LarsonDavis.com

**REPORTE TÉCNICO DECRETO SUPREMO N°38/11 DEL MINISTERIO DEL MEDIO AMBIENTE**

Establece Norma de Emisión de Ruidos Generados por Fuentes que Indica

**FICHA DE INFORMACIÓN DE MEDICIÓN DE RUIDO**

**IDENTIFICACIÓN DE LA FUENTE EMISORA DE RUIDO**

Nombre o razón social	Comercial Successo Limitada		
RUT	79.605.490-5		
Dirección	Almirante Pastene 92 - 118		
Comuna	Providencia		
Nombre de Zona de emplazamiento (según IPT vigente)	UpEC, Uso preferentemente Equipamiento Comercial		
Datum	WGS84	Huso	19S
Coordenada Norte	6300125.09 m	Coordenada Este	349385.13 m

**CARACTERIZACIÓN DE LA FUENTE EMISORA DE RUIDO**

Actividad Productiva	<input type="checkbox"/> Industrial	<input type="checkbox"/> Agrícola	<input type="checkbox"/> Extracción	<input type="checkbox"/> Otro
Actividad Comercial	<input type="checkbox"/> Restaurant	<input type="checkbox"/> Taller Mecánico	<input type="checkbox"/> Local Comercial	<input type="checkbox"/> Otro
Actividad Esparcimiento	<input type="checkbox"/> Discoteca	<input type="checkbox"/> Recinto Deportivo	<input type="checkbox"/> Cultura	<input type="checkbox"/> Otro
Actividad de Servicio	<input type="checkbox"/> Religioso	<input type="checkbox"/> Salud	<input type="checkbox"/> Comunitario	<input type="checkbox"/> Otro
Infraestructura Transporte	<input type="checkbox"/> Terminal	<input type="checkbox"/> Taller de Transporte	<input type="checkbox"/> Estación Intermedia	<input type="checkbox"/> Otro
Infraestructura Sanitaria	<input type="checkbox"/> Planta de Tratamiento	<input type="checkbox"/> Relleno Sanitario	<input type="checkbox"/> Instalación de Distribución	<input type="checkbox"/> Otro
Infraestructura Energética	<input type="checkbox"/> Generadora	<input type="checkbox"/> Distribución Eléctrica	<input type="checkbox"/> Comunicaciones	<input type="checkbox"/> Otro
Faena Constructiva	<input checked="" type="checkbox"/> Construcción	<input type="checkbox"/> Demolición	<input type="checkbox"/> Reparación	<input type="checkbox"/> Otro
Otro (Especificar)				

**INSTRUMENTAL DE MEDICIÓN**

**Identificación sonómetro**

Marca	Larson Davis	Modelo	LXT1	N° serie	5526
Fecha de emisión Certificado de Calibración			17.01.2018		
Número de Certificado de Calibración			2018000669		

**Identificación calibrador**

Marca	Larson Davis	Modelo	CAL200	N° serie	15291
Fecha de emisión Certificado de Calibración			21.12.2017		
Número de Certificado de Calibración			2017013480		

Ponderación en frecuencia	Filtro A	Ponderación temporal	Slow
Verificación de Calibración en Terreno	<input checked="" type="checkbox"/> Si	<input type="checkbox"/> No	

*Se deberá adjuntar Certificado de Calibración Periódica Vigente para ambos instrumentos.*

**REPORTE TÉCNICO DECRETO SUPREMO N°38/11 DEL MINISTERIO DEL MEDIO AMBIENTE**

Establece Norma de Emisión de Ruidos Generados por Fuentes que Indica

**FICHA DE INFORMACIÓN DE MEDICIÓN DE RUIDO**

**IDENTIFICACIÓN DEL RECEPTOR**

Receptor N°1	Lucile Del Carmen Cohn Valenzuela				
Rut	4.370.321-9				
Calle	Providencia				
Número	1336, depto. 121-A				
Comuna	Providencia				
Fono	944496206				
E-Mail	No tiene				
Datum	WGS84	Huso	19 S		
Coordenada Norte	6399107.30 m	Coordenada Este	3493740.05 m		
Nombre de Zona de emplazamiento	UpEC, Uso preferentemente Equipamiento Comercial				
N° de Certificado de Informaciones Previas*					
Zonificación DS N° 38/11 MMA	<input type="checkbox"/> I	<input type="checkbox"/> II	<input checked="" type="checkbox"/> III	<input type="checkbox"/> IV	<input type="checkbox"/> Rural

\* Adjuntar Certificado de Informaciones Previas (Si corresponde, según consideraciones de Art. 8°, D.S. N° 38/11 MMA)

**CONDICIONES DE MEDICIÓN**

Fecha medición	29.03.19				
Hora inicio medición	10:39 hrs				
Hora término medición	11:00 hrs				
Periodo de medición	<input checked="" type="checkbox"/> 7:00 a 21:00 h	<input type="checkbox"/> 21:00 a 7:00 h			
Lugar de medición	<input type="checkbox"/> Medición Interna	<input checked="" type="checkbox"/> Medición Externa			
Descripción del lugar de medición	Balcón				
Condiciones de ventana (en caso de medición interna)	<input type="checkbox"/> Ventana Abierta	<input type="checkbox"/> Ventana Cerrada			
Identificación ruido de fondo	Tránsito leve				
Temperatura [°C]	19	Humedad [%]	56	Velocidad de viento [m/s]	1,38

Nombre y firma Inspector Ambiental (IA)	Daniel Arenas González Ingeniero de Ejecución en Sonido	
Entidad Técnica de Fiscalización Ambiental	Municipalidad de Providencia	

**Nota:**

- Se deberá imprimir y completar esta página para cada receptor evaluado.
- Se podrán incluir fotografías del punto donde se ubique el sonómetro para la realización de la medición.
- Los datos de Temperatura, Humedad Relativa y Velocidad de viento, corresponderá para mediciones realizadas en el exterior.

**FICHA DE GEORREFERENCIACIÓN DE MEDICIÓN DE RUIDO**

Croquis

Imagen Satelital



Origen de la imagen Satelital

Google Earth

Escala de la imagen Satelital

**LEYENDA DE CROQUIS O IMAGEN UTILIZADA**

Datum		WGS84		Huso		19 S	
Fuentes				Receptores			
Símbolo	Nombre	Coordenadas		Símbolo	Nombre	Coordenadas	
C	Construcción	N	6300125.09 m	R	Reclamante (Punto de medición)	N	6300125.09 m
		E	349385.13 m			E	349385.13 m

Se podrán adjuntar fotografías, considerando como máximo una (1) por fuente y dos (2) por lugar de medición.

**REPORTE TÉCNICO DECRETO SUPREMO N°38/11 DEL MINISTERIO DEL MEDIO AMBIENTE**

Establece Norma de Emisión de Ruidos Generados por Fuentes que Indica

**FICHA DE MEDICIÓN DE NIVELES DE RUIDO**

**REGISTRO DE MEDICIÓN DE RUIDO DE FUENTE EMISORA**

Identificación Receptor N°	1
<input type="checkbox"/> Medición Interna (tres puntos)	<input checked="" type="checkbox"/> Medición externa (un punto)

	NPSeq		NPSmin		NPSmáx
Punto 1	88,8	→	82,5	→	91,2
	87	→	85	→	88,4
	86	→	73	→	90,4
	NPSeq		NPSmin		NPSmáx
Punto 2		→		→	
		→		→	
		→		→	
	NPSeq		NPSmin		NPSmáx
Punto 3		→		→	
		→		→	
		→		→	

**REGISTRO DE RUIDO DE FONDO**

Ruido de fondo afecta la medición	<input type="checkbox"/> Si	<input checked="" type="checkbox"/> No
Fecha:	29.03.19	Hora: 11:20 hrs

	5'	10'	15'	20'	25'
NPSeq	53	54			

**Observaciones:**

---



---



---

**FICHA DE EVALUACIÓN DE NIVELES DE RUIDO**

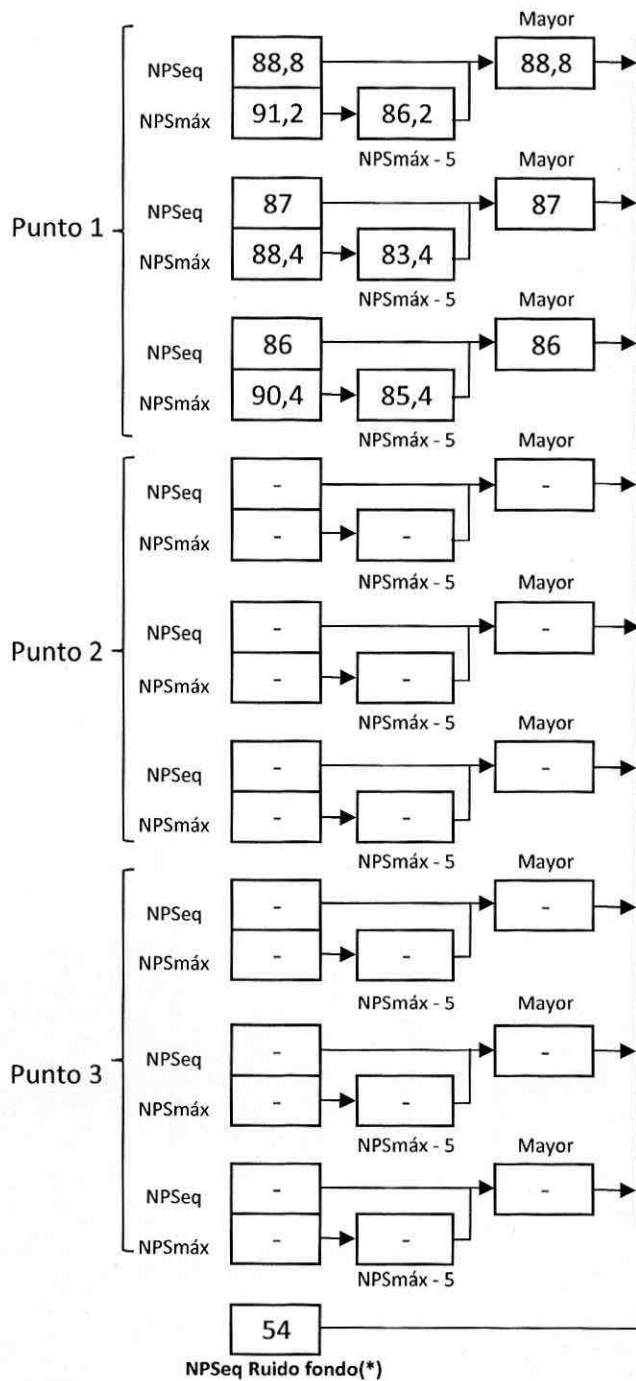

Información del Receptor	
Identificación del Receptor N°	1
Indicar Condiciones	
Medición	Exterior
Ventana	No Aplica
Modelación ISO 9613	
No	

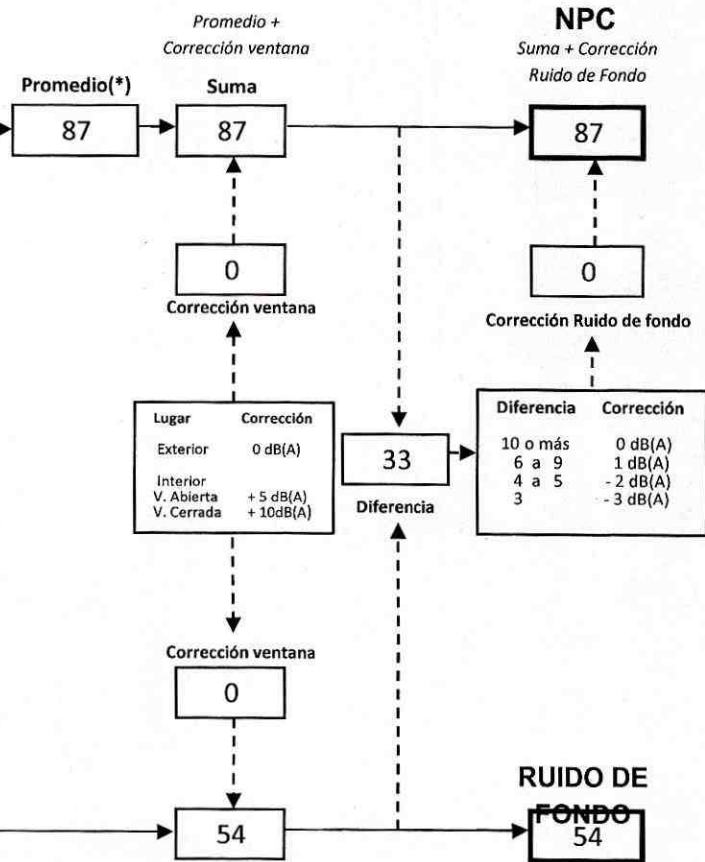

(\*) Aproximar a números enteros

REPORTE TÉCNICO DECRETO SUPREMO N°38/11 DEL MINISTERIO DEL MEDIO AMBIENTE

Establece Norma de Emisión de Ruidos Generados por Fuentes que Indica

FICHA DE EVALUACIÓN DE NIVELES DE RUIDO

TABLA DE EVALUACIÓN

Receptor N°	NPC [dBA]	Ruido de Fondo [dBA]	Zona DS N°38	Periodo (Diurno/Nocturno)	Límite [dBA]	Estado (Supera/No Supera)
1	87	54	III	Diurno	65	Supera

OBSERVACIONES

Fuente de ruido: Perforadora

Caso derivado anteriormente a la SMA, debido a denuncia de don José Díaz Del Río. Se adjunta acta por denuncia de reclamante Lucile Cohn y acta entregada a la Constructora el 20.03.19, producto de la denuncia de Don José Díaz Del Río. Al momento de la visita, la construcción se encontraba en la etapa de excavación y fundación. En la fotografía de abajo se señala la perforadora, encargada de perforar los pilares de acero que son la base de la estructura. Según lo conversado con el jefe de obra, esta etapa duraría aproximadamente un mes más.

Se adjunta nuevamente acta firmada por vecinos del edificio ubicado en Manuel Montt 051

ANEXO - Forografía de la obra

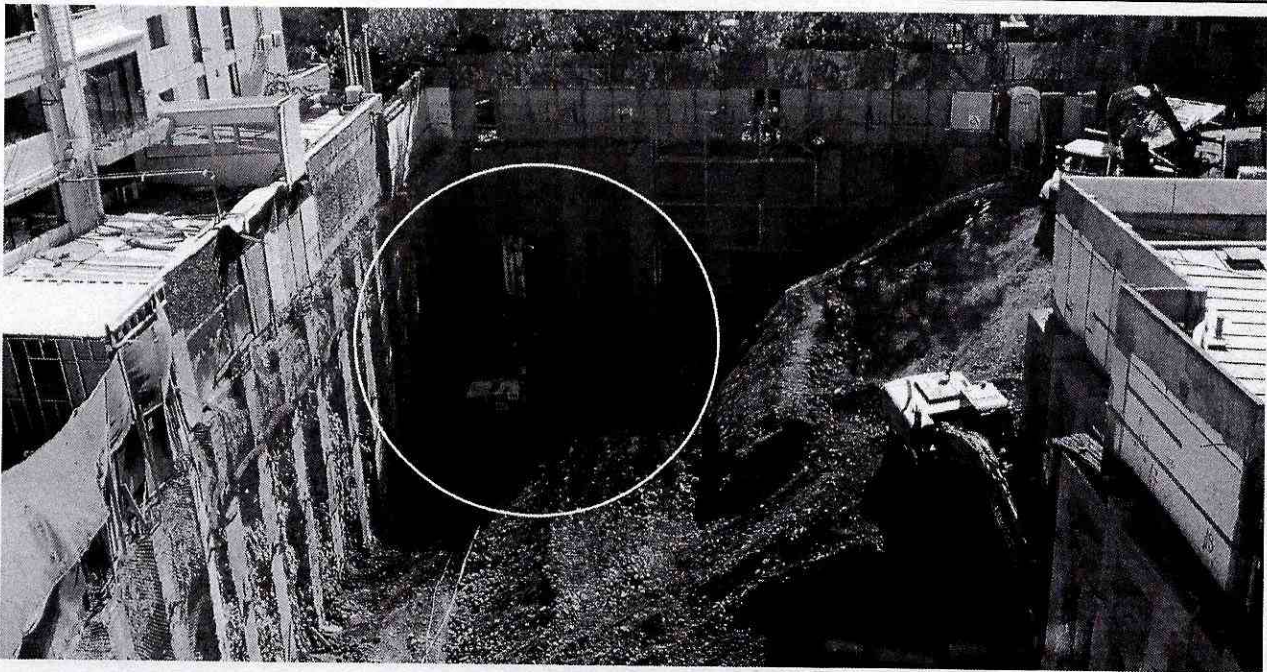

RESPONSABLE DEL REPORTE (Llenar sólo ETFA)

Fecha del reporte	
Nombre Representante Legal	
Firma Representante Legal	



# Calibration Certificate

Certificate Number 2018000669

**Customer:**

Sistemas De Instrumentacion  
Concha Y Toro NO 65  
Santiago-Centro  
Santiago, Chile

**Model Number** LxT1  
**Serial Number** 0005526  
**Test Results** Pass

**Initial Condition** As Manufactured

**Description** SoundTrack LxT Class 1  
Class 1 Sound Level Meter  
Firmware Revision: 2.302

**Procedure Number** D0001.8384  
**Technician** Ron Harris  
**Calibration Date** 17 Jan 2018  
**Calibration Due** 17 Jan 2020  
**Temperature** 23.33 °C ± 0.25 °C  
**Humidity** 50.7 %RH ± 2.0 %RH  
**Static Pressure** 87.08 kPa ± 0.13 kPa

**Evaluation Method**

**Tested with:**

Larson Davis PRMLxT1, S/N 046806  
PCB 377B02, S/N 177005  
Larson Davis CAL200, S/N 9079  
Larson Davis CAL291, S/N 0203

**Data reported in dB re 20 µPa.**

**Compliance Standards**

Compliant to Manufacturer Specifications and the following standards when combined with Calibration Certificate from procedure D0001.8378:

IEC 60651:2001 Type 1	ANSI S1.4-2014 Class 1
IEC 60804:2000 Type 1	ANSI S1.4 (R2006) Type 1
IEC 61252:2002	ANSI S1.11 (R2009) Class 1
IEC 61260:2001 Class 1	ANSI S1.25 (R2007)
IEC 61672:2013 Class 1	ANSI S1.43 (R2007) Type 1

Issuing lab certifies that the instrument described above meets or exceeds all specifications as stated in the referenced procedure (unless otherwise noted). It has been calibrated using measurement standards traceable to the International System of Units (SI) through the National Institute of Standards and Technology (NIST), or other national measurement institutes, and meets the requirements of ISO/IEC 17025:2005.

Test points marked with a ‡ in the uncertainties column do not fall within this laboratory's scope of accreditation.

The quality system is registered to ISO 9001:2008.

This calibration is a direct comparison of the unit under test to the listed reference standards and did not involve any sampling plans to complete. No allowance has been made for the instability of the test device due to use, time, etc. Such allowances would be made by the customer as needed.

The uncertainties were computed in accordance with the ISO Guide to the Expression of Uncertainty in Measurement (GUM). A coverage factor of approximately 2 sigma (k=2) has been applied to the standard uncertainty to express the expanded uncertainty at approximately 95% confidence level.

This report may not be reproduced, except in full, unless permission for the publication of an approved abstract is obtained in writing from the organization issuing this report.

Correction data from Larson Davis LxT Manual for SoundTrack LxT & SoundExpert LxT, 1770.01 Rev J Supporting Firmware Version 2.301, 2015-04-30

Larson Davis, a division of PCB Piezotronics, Inc  
1681 West 820 North  
Provo, UT 84601, United States  
716-684-0001



**Certificate Number 2018000669**

For 1/4" microphones, the Larson Davis ADP024 1/4" to 1/2" adaptor is used with the calibrators and the Larson Davis ADP043 1/4" to 1/2" adaptor is used with the preamplifier.

Calibration Check Frequency: 1000 Hz; Reference Sound Pressure Level: 114 dB re 20 µPa

Periodic tests were performed in accordance with procedures from IEC 61672-3:2013 / ANSI/ASA S1.4-2014/Part 3.

Pattern approval for IEC 61672-1:2013 / ANSI/ASA S1.4-2014/Part 1 successfully completed by Physikalisch-Technische Bundesanstalt (PTB) on 2007-10-09 reference number PTB-1.72-4034218.

The sound level meter submitted for testing successfully completed the periodic tests of IEC 61672-3:2013 / ANSI/ASA S1.4-2014/Part 3, for the environmental conditions under which the tests were performed. As evidence was publicly available, from an independent testing organization responsible for approving the results of pattern-evaluation tests performed in accordance with IEC 61672-2:2013 / ANSI/ASA S1.4-2014/Part 2, to demonstrate that the model of sound level meter fully conformed to the class 1 specifications in IEC 61672-1:2013 / ANSI/ASA S1.4-2014/Part 1; the sound level meter submitted for testing conforms to the class 1 specifications in IEC 61672-1:2013 / ANSI/ASA S1.4-2014/Part 1.

Standards Used			
Description	Cal Date	Cal Due	Cal Standard
SRS DS360 Ultra Low Distortion Generator	2017-06-23	2018-06-23	006311
Hart Scientific 2626-S Humidity/Temperature Sensor	2017-06-11	2018-06-11	006943
Larson Davis CAL200 Acoustic Calibrator	2017-07-25	2018-07-25	007027
Larson Davis Model 831	2017-03-01	2018-03-01	007182
PCB 377A13 1/2 inch Prepolarized Pressure Microphone	2017-03-08	2018-03-08	007185
Larson Davis CAL291 Residual Intensity Calibrator	2017-09-19	2018-09-19	007287

**Acoustic Calibration**

Measured according to IEC 61672-3:2013 10 and ANSI S1.4-2014 Part 3: 10

Measurement	Test Result [dB]	Lower Limit [dB]	Upper Limit [dB]	Expanded Uncertainty [dB]	Result
1000 Hz	114.00	113.80	114.20	0.14	Pass

**Acoustic Signal Tests, C-weighting**

Measured according to IEC 61672-3:2013 12 and ANSI S1.4-2014 Part 3: 12 using a comparison coupler with Unit Under Test (UUT) and reference SLM using slow time-weighted sound level for compliance to IEC 61672-1:2013 5.5; ANSI S1.4-2014 Part 1: 5.5

Frequency [Hz]	Test Result [dB]	Expected [dB]	Lower Limit [dB]	Upper Limit [dB]	Expanded Uncertainty [dB]	Result
125	-0.22	-0.20	-1.20	0.80	0.23	Pass
1000	0.18	0.00	-0.70	0.70	0.23	Pass
8000	-2.61	-3.00	-5.50	-1.50	0.32	Pass

— End of measurement results—

**Self-generated Noise**

Measured according to IEC 61672-3:2013 11.1 and ANSI S1.4-2014 Part 3: 11.1

Measurement	Test Result [dB]
A-weighted	40.63

— End of measurement results—

Larson Davis, a division of PCB Piezotronics, Inc  
1681 West 820 North  
Provo, UT 84601, United States  
716-684-0001



# Calibration Certificate

Certificate Number 2017013480

**Customer:**  
Sistemas De Instrumentacion  
Concha Y Toro NO 65  
Santiago-Centro  
Santiago, Chile

**Model Number** CAL200  
**Serial Number** 15291  
**Test Results** Pass  
**Initial Condition** As Manufactured  
**Description** Larson Davis CAL200 Acoustic Calibrator

**Procedure Number** D0001.8386  
**Technician** Scott Montgomery  
**Calibration Date** 21 Dec 2017  
**Calibration Due** 21 Dec 2019  
**Temperature** 22 °C ± 0.3 °C  
**Humidity** 32 %RH ± 3 %RH  
**Static Pressure** 101.3 kPa ± 1 kPa

**Evaluation Method** The data is acquired by the insert voltage calibration method using the reference microphone's open circuit sensitivity. Data reported in dB re 20 µPa.

**Compliance Standards** Compliant to Manufacturer Specifications per D0001.8190 and the following standards:  
IEC 60942:2003 ANSI S1.40-2006

Issuing lab certifies that the instrument described above meets or exceeds all specifications as stated in the referenced procedure (unless otherwise noted). It has been calibrated using measurement standards traceable to the SI through the National Institute of Standards and Technology (NIST), or other national measurement institutes, and meets the requirements of ISO/IEC 17025:2005. Test points marked with a ± in the uncertainties column do not fall within this laboratory's scope of accreditation.

The quality system is registered to ISO 9001:2008.

This calibration is a direct comparison of the unit under test to the listed reference standards and did not involve any sampling plans to complete. No allowance has been made for the instability of the test device due to use, time, etc. Such allowances would be made by the customer as needed.

The uncertainties were computed in accordance with the ISO Guide to the Expression of Uncertainty in Measurement (GUM). A coverage factor of approximately 2 sigma (k=2) has been applied to the standard uncertainty to express the expanded uncertainty at approximately 95% confidence level.

This report may not be reproduced, except in full, unless permission for the publication of an approved abstract is obtained in writing from the organization issuing this report.

### Standards Used

Description	Cal Date	Cal Due	Cal Standard
Agilent 34401A DMM	09/06/2017	09/06/2018	001021
Larson Davis Model 2900 Real Time Analyzer	04/10/2017	04/10/2018	001051
Microphone Calibration System	08/08/2017	08/08/2018	005446
1/2" Preamplifier	10/05/2017	10/05/2018	006506
Larson Davis 1/2" Preamplifier 7-pin LEMO	08/08/2017	08/08/2018	006507
1/2 inch Microphone - RI - 200V	04/24/2017	04/24/2018	006510
Pressure Transducer	06/01/2017	06/01/2018	007310

-- End of Report--

Signatory: Ron Harris

Larson Davis, a division of PCB Piezotronics, Inc  
1681 West 820 North  
Provo, UT 84601, United States  
716-684-0001



**LARSON DAVIS**  
A PCB PIEZOTRONICS DIV.

Larson Davis, a division of PCB Piezotronics, Inc  
1681 West 820 North  
Provo, UT 84601, United States  
716-684-0001



**LARSON DAVIS**  
A PCB PIEZOTRONICS DIV.

Certificate Number 2017013480

**Output Level**

Nominal Level [dB]	Pressure [kPa]	Test Result [dB]	Lower limit [dB]	Upper limit [dB]	Expanded Uncertainty [dB]	Result
114	101.3	114.00	113.80	114.20	0.13	Pass
94	101.3	94.01	93.80	94.20	0.14	Pass

-- End of measurement results--

**Frequency**

Nominal Level [dB]	Pressure [kPa]	Test Result [Hz]	Lower limit [Hz]	Upper limit [Hz]	Expanded Uncertainty [Hz]	Result
94	101.3	1,000.10	990.00	1,010.00	0.20	Pass
114	101.3	1,000.09	990.00	1,010.00	0.20	Pass

-- End of measurement results--

**Total Harmonic Distortion + Noise (THD+N)**

Nominal Level [dB]	Pressure [kPa]	Test Result [%]	Lower limit [%]	Upper limit [%]	Expanded Uncertainty [%]	Result
94	101.3	0.42	0.00	2.00	0.25	Pass
114	101.3	0.38	0.00	2.00	0.25	Pass

-- End of measurement results--

**Level Change Over Pressure**

Tested at: 114 dB, 23 °C, 28 %RH

Nominal Pressure [kPa]	Pressure [kPa]	Test Result [dB]	Lower limit [dB]	Upper limit [dB]	Expanded Uncertainty [dB]	Result
101.3	101.1	0.00	-0.30	0.30	0.04 ‡	Pass
92.0	92.0	0.00	-0.30	0.30	0.04 ‡	Pass
108.0	108.0	-0.02	-0.30	0.30	0.04 ‡	Pass
83.0	83.2	-0.01	-0.30	0.30	0.04 ‡	Pass
74.0	74.1	-0.06	-0.30	0.30	0.04 ‡	Pass
65.0	65.1	-0.14	-0.30	0.30	0.04 ‡	Pass

-- End of measurement results--

**Frequency Change Over Pressure**

Tested at: 114 dB, 23 °C, 28 %RH

Nominal Pressure [kPa]	Pressure [kPa]	Test Result [Hz]	Lower limit [Hz]	Upper limit [Hz]	Expanded Uncertainty [Hz]	Result
108.0	108.0	0.00	-10.00	10.00	0.20 ‡	Pass
101.3	101.1	0.00	-10.00	10.00	0.20 ‡	Pass
92.0	92.0	0.00	-10.00	10.00	0.20 ‡	Pass
83.0	83.2	-0.01	-10.00	10.00	0.20 ‡	Pass
74.0	74.1	-0.01	-10.00	10.00	0.20 ‡	Pass
65.0	65.1	-0.02	-10.00	10.00	0.20 ‡	Pass

-- End of measurement results--

Larson Davis, a division of PCB Piezotronics, Inc  
1681 West 820 North  
Provo, UT 84601, United States  
716-684-0001



**LARSON DAVIS**  
A PCB PIEZOTRONICS DIV.

Certificate Number 2017013480

**Total Harmonic Distortion + Noise (THD+N) Over Pressure**

Tested at: 114 dB, 23 °C, 28 %RH

Nominal Pressure [kPa]	Pressure [kPa]	Test Result [%]	Lower limit [%]	Upper limit [%]	Expanded Uncertainty [%]	Result
108.0	108.0	0.39	0.00	2.00	0.25 ‡	Pass
101.3	101.1	0.38	0.00	2.00	0.25 ‡	Pass
92.0	92.0	0.37	0.00	2.00	0.25 ‡	Pass
83.0	83.2	0.36	0.00	2.00	0.25 ‡	Pass
74.0	74.1	0.36	0.00	2.00	0.25 ‡	Pass
65.0	65.1	0.36	0.00	2.00	0.25 ‡	Pass

-- End of measurement results--

Signatory: *Scott Montgomery*

Larson Davis, a division of PCB Piezotronics, Inc  
1681 West 820 North  
Provo, UT 84601, United States  
716-684-0001



**LARSON DAVIS**  
A PCB PIEZOTRONICS DIV.



### Model CAL200 Relative SPL vs. Temperature

Larson Davis Model CAL200 Serial Number: 15291

Model CAL200 Relative SPL vs. Temperature at 50% RH.  
A 2559 Mic (SN: 2995) with a PRM902 Preamp (SN: 5726), station 19 was used to check the levels.

Test Date: 05 Dec 2017 17:42:11

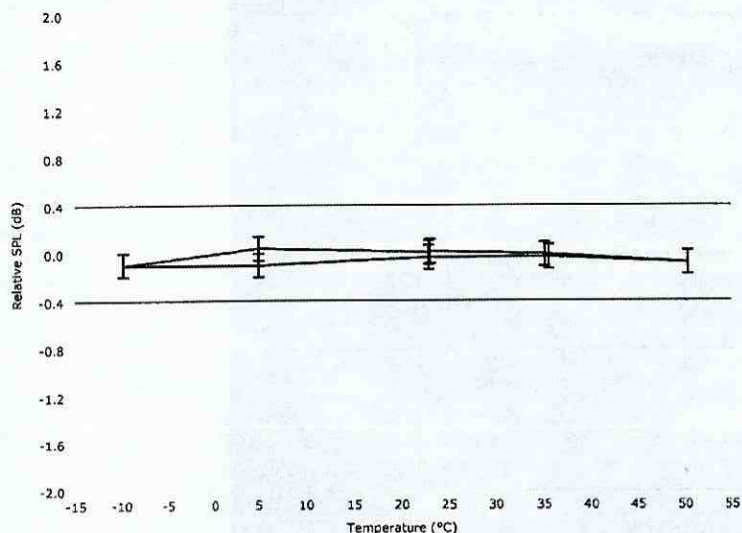

0.1dB expanded uncertainty at ~95% confidence level (k=2)

Sequence File: CAL200.SEQ

Test Location: Larson Davis, a division of PCB Piezotronics, Inc.  
1681 West 820 North, Provo, Utah 84601  
Tel: 716 684-0001 www.LarsonDavis.com



### Model CAL200 Relative Frequency vs. Temperature

Larson Davis Model CAL200 Serial Number: 15291

Model CAL200 Relative Frequency vs. Temperature at 50% RH.  
A 2559 Mic (SN: 2995) with a PRM902 Preamp (SN: 5726), station 19 was used to check the levels.

Test Date: 05 Dec 2017 17:42:11

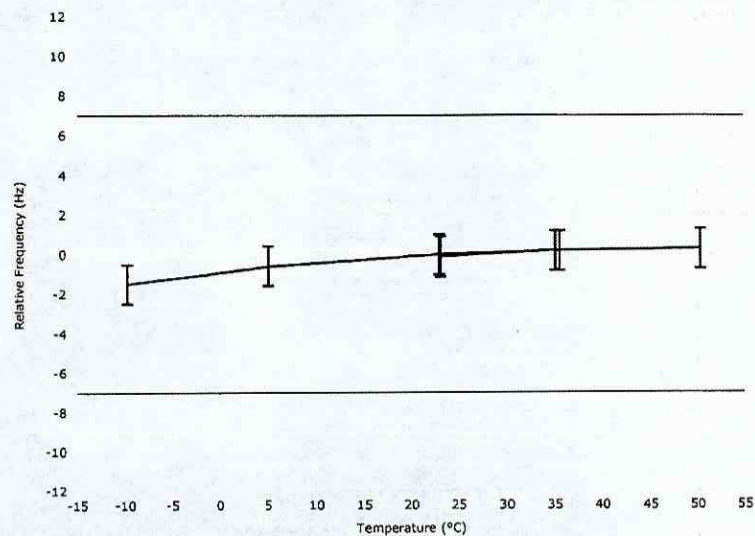

1.0 Hz expanded uncertainty at ~95% confidence level (k=2)

Sequence File: CAL200.SEQ

Test Location: Larson Davis, a division of PCB Piezotronics, Inc.  
1681 West 820 North, Provo, Utah 84601  
Tel: 716 684-0001 www.LarsonDavis.com